



A **VANTAGE** Company

ONE COMPANY. SO MANY OPTIONS.

Freight Doors • Car Gates • Car Enclosures



WARNING

Courion®
St. Louis, Missouri, USA
1-800-523-5760

Courion®
MODEL LP25₂ MOTOR
230 VAC - 3PH - 60 HZ
600 RPM - 1.4 A - CLASS H
SPEC NO. W1821
DATE CODE: FX

FREIGHT DOORS..... 4

iLEARN5

iDRIVE6

iSENSOR.....7

iWIRE.....8

Standard Features9

Door Selection 11

Door Construction..... 11

Hoistway Jamb and Wall Requirements 12

Minimum Space Requirements 13

Fire Door and Frame Construction 13

Power Arrangement..... 14

Manual Arrangement..... 14

Vertical Bi-Parting Freight Doors 15

Slide-Up Freight Doors 16

NEMA Electrical Enclosure Designations 17

Loading & Classes 18

Freight Doors & The Americans with Disabilities Act 19

Freight Elevator Door Controller 19

CAR GATES 20

Gate System Layout 20

Gate System Features..... 21

Minimum Space Requirements 22

CAR ENCLOSURES 23

SPECIFICATIONS 24

REQUEST FOR CAB QUOTE 26

REQUEST FOR DOOR QUOTE..... 27

HOISTWAY SURVEY 28

CART-MATIC CART SYSTEM..... 29

The CART-MATIC Benefits..... 32

DUMBWAITER SURVEY 33

COPYRIGHT AND DATA POLICY - COURION, the worldwide leading manufacturer of freight elevator doors, freight car enclosures, and the CART-MATIC and TOTE-MATIC automatic distribution units, reserves all rights with respect to its registered copyrights on the materials presented in the Courion Product Brochure and Courion Product Data Compact Disk. Consequently, no part of this publication may be reproduced, copied or transmitted in any form or by any means -- including any information and storage retrieval system without prior written permission from COURION. Unlawful reproduction of the contents, imitation for commercial purposes or willful infringement of these copyrights will result in prosecution of the infringing party or parties under the copyright laws of the United States and the international treaties and conventions which apply. Inquiries concerning copyright information on the COURION Product Brochure and Product Data Compact Disk may be directed to COURION at 3044 Lambdin Avenue, St. Louis, Missouri 63115.



A **VANTAGE** Company

3044 Lambdin Ave.
 St. Louis, Missouri 63115
 Ph: 314.533.5700 | 800.533.5760
 Fax: 314.533.5720
 sales@couriondoors.com
www.couriondoors.com

VANTAGE REGIONAL SERVICE CENTERS
 Miami – 877.241.9354
 Chicago – 877.300.5830
 Los Angeles – 877.300.5816
 New York – 347.226.4555
 Toronto – 888.425.2262

FREIGHT DOORS

Freight Door Layout

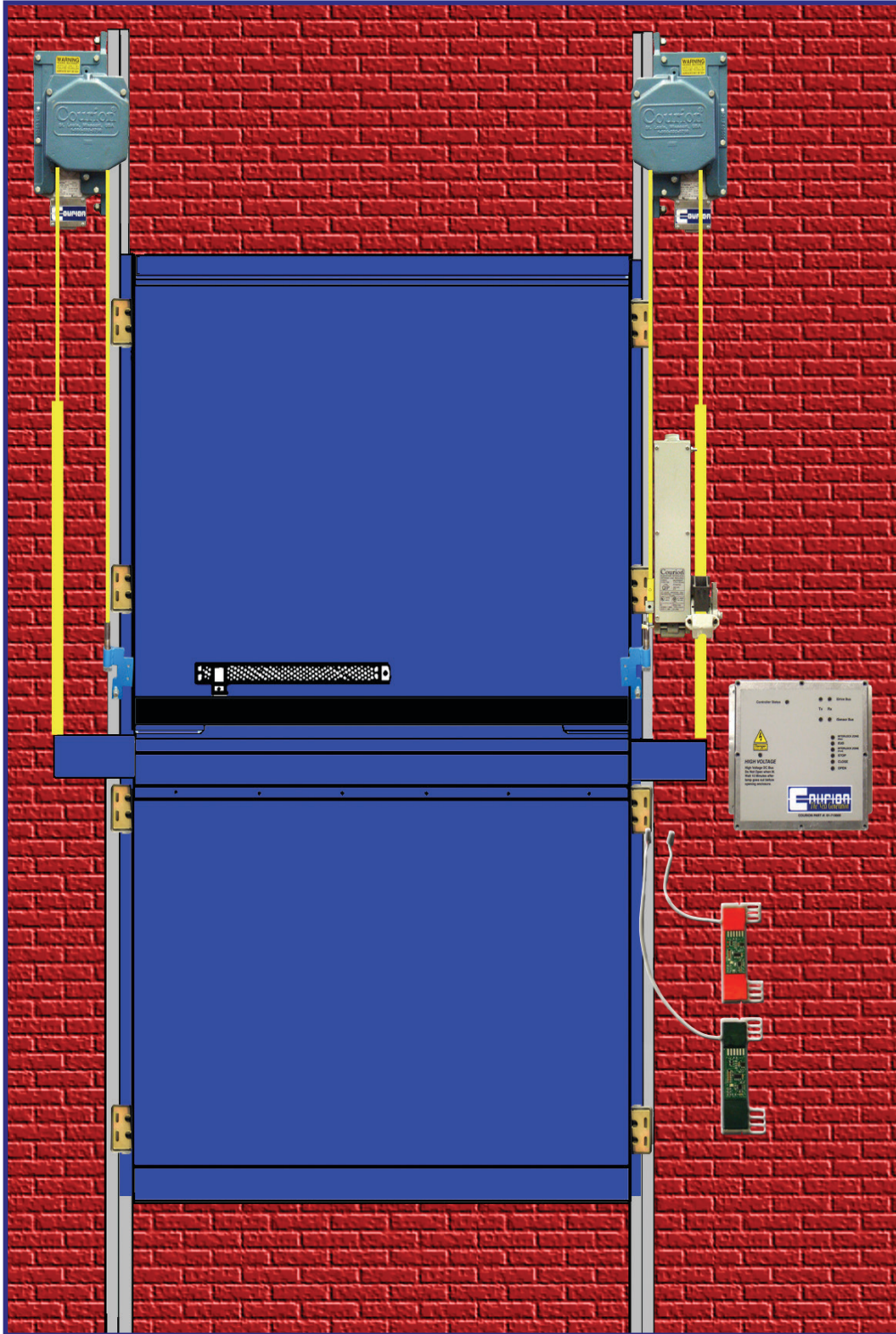

LP25 Operator



i-DRIVE Floor Control



Q Interlock



LF96 Door Shoes



i-SENSOR Door Positioner

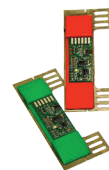

iLEARN

Door Control

Don't let the small size fool you! This is the smartest Freight Elevator Door Control available in today's market.

SMALL

COURION's new iLEARN Door Control measures 5"x8"x3". Because of its small size, the iLEARN Door Control can be mounted inside most Elevator Controls.

SMART

The iLEARN Door Control is micro-processor based with custom software that automatically adjusts the doors to ensure the smooth and quiet performance of your COURION equipment.

MEMORY

The iLEARN Door Control collects and records door and car gate operational data. This information can be viewed by the field mechanic on the iLEARN Control's display or can be downloaded via the integrated USB port.

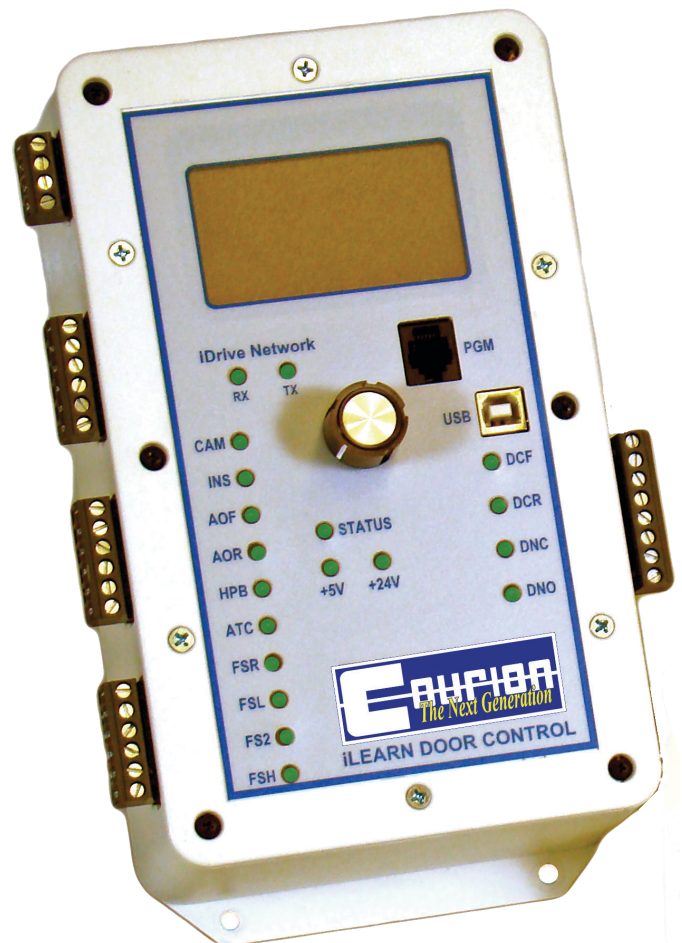

iDRIVE

VFD Motor Control

No more slamming Freight Elevator Doors. Your COURION Doors will run smoothly and quietly every time.

SMOOTH OPERATION

The iDRIVE VFD Motor Control provides floor specific variable frequency drive control to COURION’s Door and Car Gate Motors. The variable frequency technology utilized by the iDRIVE VFD Motor Control guarantees the smooth and quiet operation of your hoistway doors and car gate every time.

SELF-ADJUSTING

The iDRIVE VFD Motor Control, in connection with the iLEARN Door Control, automatically sets up and adjusts your freight elevator hoistway doors and car gate for you. Plug it in, turn it on, and walk away - it is that simple.

DIAGNOSTIC DISPLAY

The iDRIVE VFD Motor Control is equipped with twelve (12) LED indicator lights that provide instant feedback to the field mechanic. With just one look, a mechanic can identify and correct any electrical problem associated with the COURION equipment.

SIMPLE TO INSTALL

The iDRIVE VFD Motor Control mounts directly to the hoistway door guides. Simply attach the COURION Communication Cable and input power cable, which are supplied to you by COURION at no additional charge, and you are ready to go.

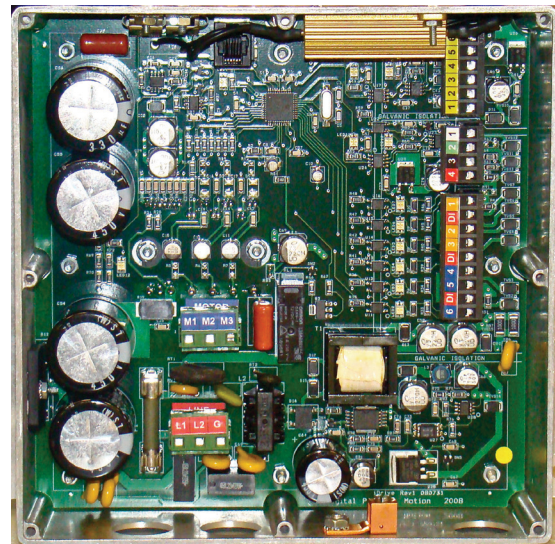
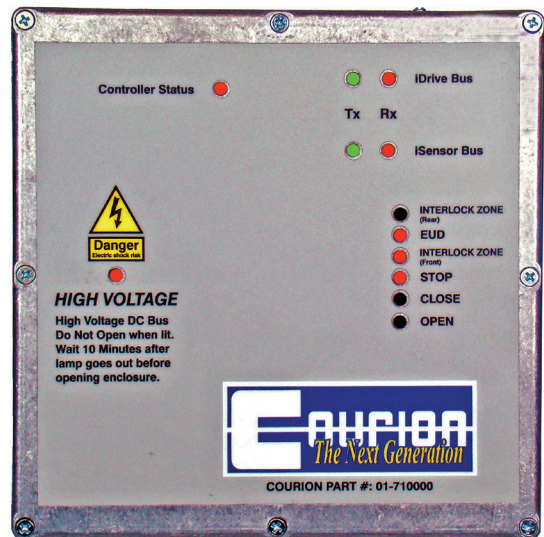

iSENSOR

Door Sensor

Courion's iSENSOR utilizes state-of-the-art hall-effect technology to accurately and reliably determine the exact position of your freight elevator hoistway doors during their operating cycle.

SOLID STATE

COURION's new iSENSOR is a solid-state door positioning device with no moving parts. In today's freight elevator hoistways, this represents a huge advantage over limit switches, proximity sensors, and yo-yo string potentiometers because there is nothing to break and nothing to adjust.

DURABLE & RELIABLE

The iSENSOR is immune to dust, oil, grease, dirt, mud, and water. These characteristics make the iSENSOR ideal for a freight elevator hoistway and superior to all other position-sensing alternatives.

FACTORY INSTALLED

The iSENSOR is factory mounted to the lower hoistway door guide. During initial installation, all the mechanic has to do is plug the iSENSOR's plug-n-play communication cable into the iDRIVE VFD Motor Control; all other adjustments are made by the COURION system itself.

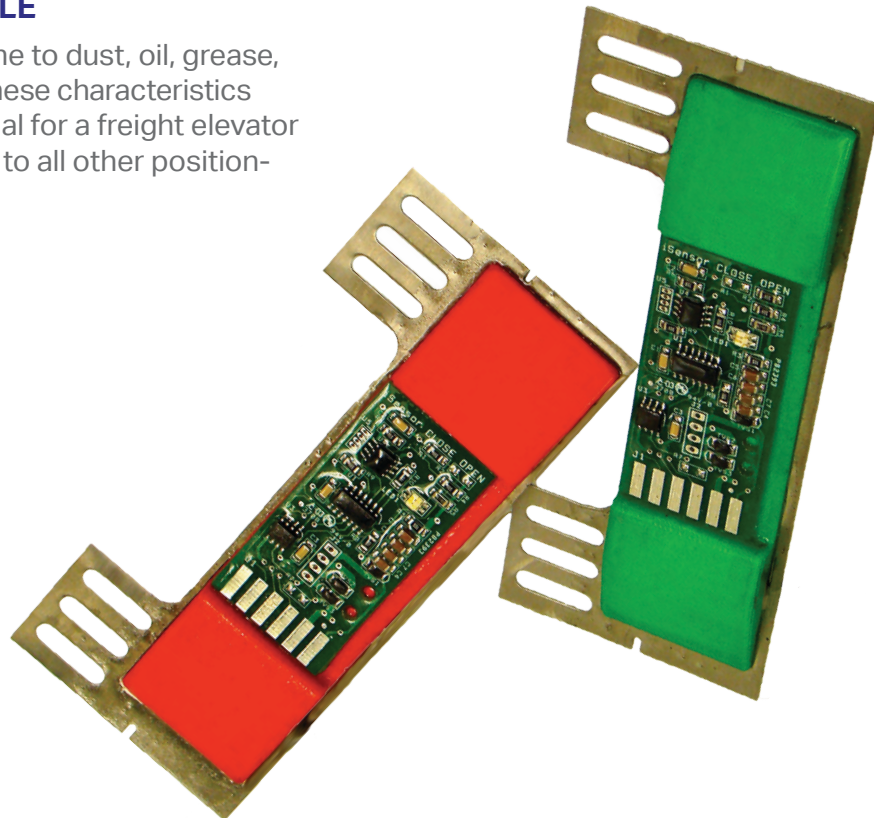

iWIRE CANBus System

Imagine reducing your hoistway wiring from sixty-six (66) hoistway wires to two (2). Now you can, with COURION's new iWIRE CANBus Serial Communication Wiring Package.

EASY TO INSTALL

Fewer wires lead to fewer problems. Installation time will be measured in hours – not days.

SIMPLIFIED TROUBLE-SHOOTING

LED indicator lights make troubleshooting a snap. GREEN means GO. RED means STOP. It is that simple.

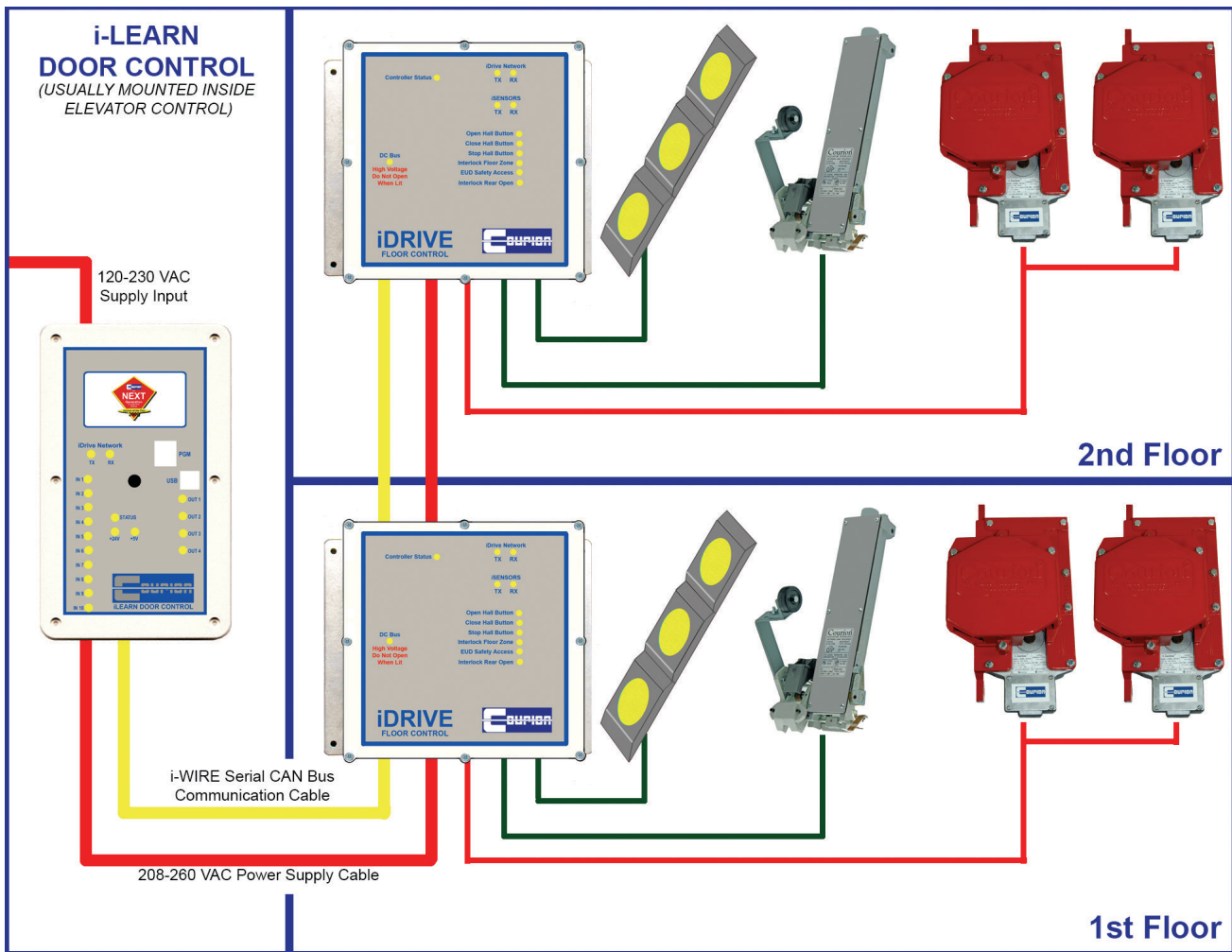

Standard Features

COURION's standard freight elevator door equipment represents the culmination of over 85 years of experience and progress in the design, manufacture, and installation of power operated freight elevator doors and gates.

DOOR OPERATOR

COURION has combined modern motor technology with design innovation to create the new LP25 Freight Door Operator. It is compact, durable, and easy to install. The motor housing is a totally enclosed, non-ventilated aluminum die cast housing with an integral junction box. The intermittent duty motor has over twice the stall rating of any similar motor in the industry.

INTERLOCKS

COURION doors are equipped with an electromechanical interlock, activated by an adjustable retiring cam. COURION's interlock is NEMA 4, 12, and 13 - standard. Devices with NEMA ratings of 4X, 7, and 9 are also available.

DOOR SHOES

COURION has finally brought freight door guide shoes out of the stone age. The COURION LF96 Guide Shoe's composite design means no more shims or small shoe pieces. The molybdenum surfaces withstand loss of lubrication and eliminates metal on metal clatter.

CARE AUTOMATIC REVERSING EDGE

COURION was the first to introduce a non-contact infrared light curtain for freight elevator doors. The CARE represents a cost effective way to reduce damage to freight elevator doors and car gates.

AUTO STA-SET

COURION's new iDRIVE Door Control automatically prevents lower door panels from being damaged when a heavy weight passes over the freight elevator entry. When activated, the iDRIVE Door Control energizes the door motors, causing the door panels to remain in the full open position and at rest.



Door Operator

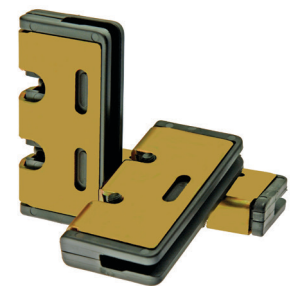

Door Shoes

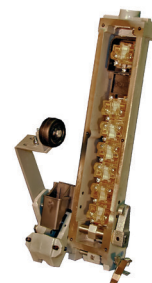

Interlocks

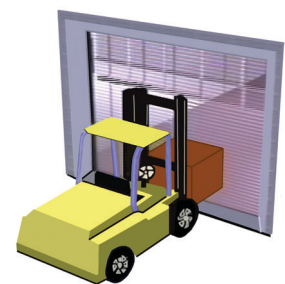

CARE Automatic Reversing Edge



Auto Sta-Set



Standard Features (Cont.)

ELECTRICAL WIRING PACKAGES

COURION now provides a customized wiring package on every job that includes COURION's "Next Generation" Freight Door and Car Gate Equipment. This wiring package includes the iWIRE Serial CANBus Communication Cable, and pre-marked floor and motor wire bundles. The iWIRE Package is tailored to your specific requirements and is provided at NO CHARGE to you.

If you have purchased something other than COURION's "Next Generation" Freight Door and Car Gate equipment, you may purchase a customized wiring package that includes pre-marked hoistway and motor wire bundles, and hoistway and cab top junction boxes with marked terminal strips. Optional items include traveling cable, conduit, and fittings.

SIDE OPPOSITE LOCKS

Side Opposite Locks are used to ensure the closed position of the door panels. They are standard on all doors that are 10' (3000mm) or wider.

SOUND REDUCTION INSULATION

To reduce the noise of freight elevator doors, COURION can apply a mastic sound-deadening coating to the hoistway side of any door panel.

DOOR PANEL FINISHES

Factory prime is standard. Also available in stainless steel and a wide range of decorative metal laminates without compromising UL ratings. Typical special finishes include:

- Air Dry Enamel (color to be specified)
- Powder Coat Enamel (color to be specified)
- #4 Stainless Steel roomside face sheet with factory prime frame
- #4 Stainless Steel roomside face sheet with 2B Stainless Frame
- 2B Stainless Steel roomside face sheet with 2B Stainless Frame

Stainless steel guide rails, chain rods and chain are also available.

INSTALLATION

FREIGHT TECH, LLC., a wholly owned subsidiary of COURION, offers "turn-key" installation and repair of any manufacturer's freight elevator door system. FREIGHT TECH is an I.U.E.C. company with its office in Long Island, New York.



Electrical Wiring Packages



Door Panel Finishes

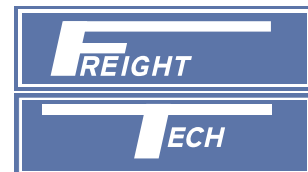

Installation

Door Selection

Doors are often subject to extremely heavy traffic and abuse. The following pages contain information about specific factors that will influence your choice of door design.

Factors include:

- Maximum size of load of the elevator
- How the elevator is loaded and unloaded
- Who will operate the doors
- How often they will be operated

Answers to these factors will help determine whether the doors should be power or manually operated. COURION recommends power operation for all doors 8'-0" x 8'-0" (2440mm x 2440mm) or larger. Most COURION manual doors can be retrofitted for power operation.

What environmental conditions must the doors withstand? This can determine the material selection. Special finishes can protect components from moisture, corrosion, or provide decorative finish options.

Door Construction

There are three (3) basic types of standard door construction available from COURION.

Steel plate (SP) panels have 12 gauge face sheets welded to reinforced structural steel frames. SP doors are UL and C-UL rated 1-1/2 hour (B).

Steel plate insulated (SPI) panels are similar to SP, with the addition of insulation and a shaft-side steel sheet covering. SPI doors are UL and C-UL rated 1-1/2 hour (B) and heat transmission rated at 650 degrees F maximum temperature rise in 30 minutes.

Metal Clad (M-6) panels have wood cores with galvanized steel coverings that provide greater fire resistance and extra resilience. M-6 doors are recommended for general commercial and heavy duty industrial use - except in wet conditions. M-6 doors are quieter and more resistant to serious damage from power trucks. M-6 doors are UL & C-UL rated 1-1/2 hour (B), and heat transmission rated at 250 degrees F maximum temperature rise in 30 minutes.

Hoistway Jamb and Wall Requirements

In designing the freight elevator shaft, architects and engineers must account for the special structural requirements of the freight door installation.

Most freight elevator hoistways are of masonry construction. Today, however, some designers are using drywall. COURION was the first supplier to offer freight elevator doors that are UL tested and approved for installation in drywall hoistways.

COURION strongly recommends all freight elevator entrances have metal sills and steel jamps that extend to the floor beam above.

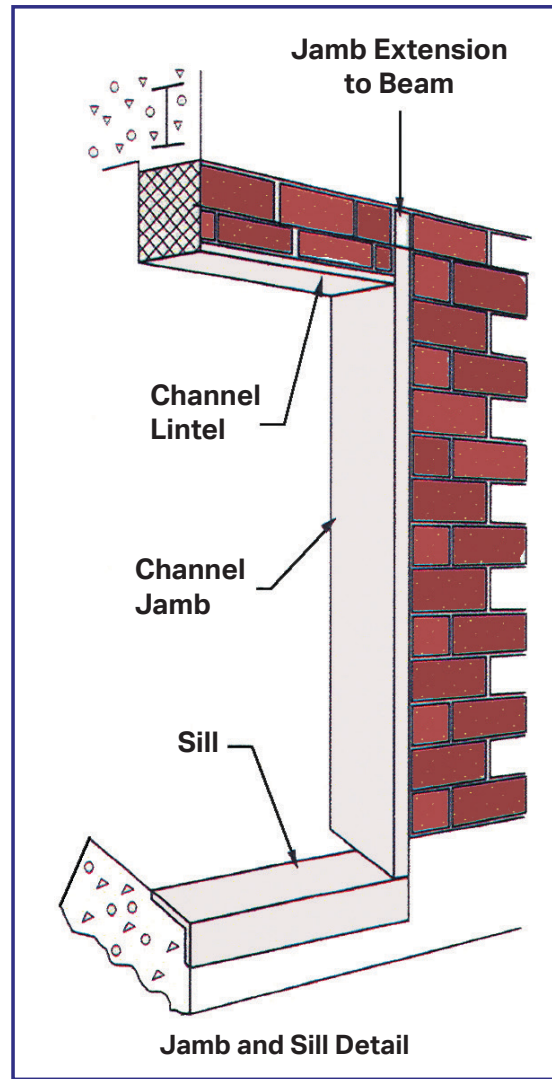
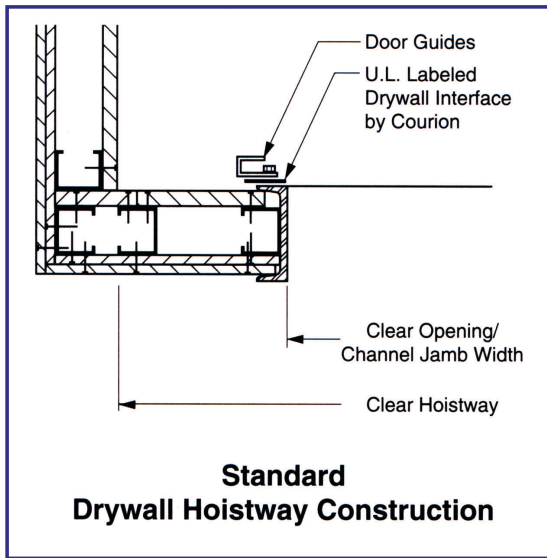

Minimum Space Requirements for Standard Courion Equipment

AREA OF HOISTWAY	REGULAR TYPE (POWER)	REGULAR TYPE (MANUAL)	PASS TYPE (POWER)	PASS TYPE (MANUAL)	1-SECTION SLIDE-UP (POWER)	2-SECTION SLIDE-UP (POWER)
LINTEL TO SILL ABOVE*	1/2 Frame Opening + 6" (153mm)	1/2 Frame Opening + 6" (153mm)	24" (610mm)	24" (610mm)	Frame Opening + 12" (305mm)	1/2 Frame Opening + 16" (406mm)
PIT DEPTH	1/2 Frame Opening + 5-1/2" (140mm)	1/2 Frame Opening + 5-1/2" (140mm)	1/2 Frame Opening + 5-1/2" (140mm)	1/2 Frame Opening + 5-1/2" (140mm)	n/a	n/a
OVERHEAD	1/2 Frame Opening + 3-1/2" (89mm)	1/2 Frame Opening + 3-1/2" (89mm)	1/2 Frame Opening + 3-1/2" (89mm)	1/2 Frame Opening + 3-1/2" (89mm)	Frame Opening + 12" (305mm)	1/2 Frame Opening + 12" (305mm)
CAR TO SILL	5" (127mm)	5" (127mm)	6-3/4" (172mm)	6-3/4" (172mm)	6-3/4" (172mm)	7-1/2" (190mm)
RETURN	12" (305mm)	11" (280mm)	12" (305mm)	12" (305mm)	13" (330mm)	13" (330mm)

*On Slide-Up doors, "Lintel to above Sill" is measured from the lintel to the underside of the above projecting sill.

These standards represent minimum space requirements for COURION's standard freight door equipment. Please contact COURION if your hoistway does not meet these minimum standards and we will be glad to provide you with a customized solution.

Fire Door and Frame Construction Approved By Underwriters Laboratories, Inc.

	UL LABELED DOORS	CERTIFIED DOORS
Masonry Hoistway		
Steel Plate & Steel Plate Insulated	13'-6" (w) x 12'-0" (h) (4115mm x 3658mm)	16'-10-1/2" (w) x 15'-0" (h) (5145mm x 4572mm)
Metal Clad (Wood Core)	8'-0" (w) x 10'-0" (h) (2440mm x 3050mm)	10'-0" (w) x 12'-0" (h) (3050mm x 3658mm)
Drywall Hoistway		
Steel Plate & Steel Plate Insulated	10'-0" (w) x 10'-6" (h) (3050mm x 3200mm)	13'-6-1/2" (w) x 13'-1-1/2" (h) (4130mm x 4000mm)
Metal Clad (Wood Core)	8'-0" (w) x 10'-0" (h) (2440mm x 3050mm)	10'-0" (w) x 12'-0" (h) (3050mm x 3658mm)

Power Arrangement

Bi-Parting Doors

Note: Division 1 locations (explosion resistant) require lap + 11" (280mm) minimum return with car lap not exceeding 4" (102mm).

Note: For car laps exceeding 7" (178mm), car lap + 5" (127mm) is required for the return.

Plan View

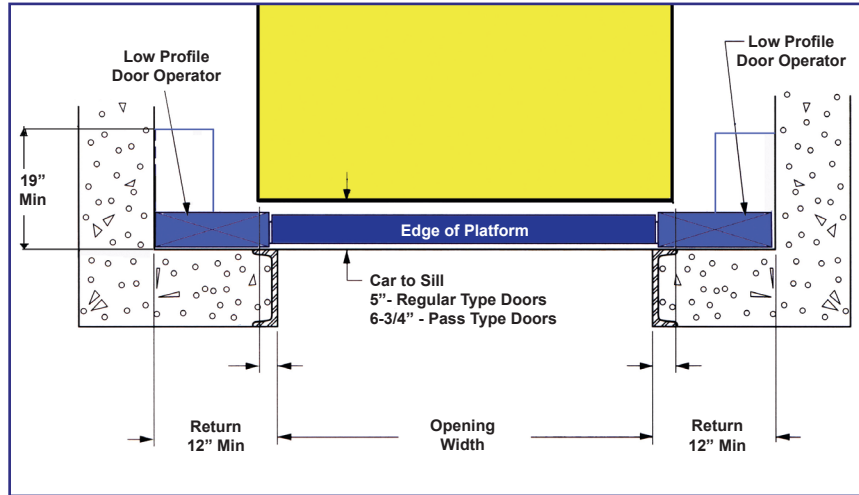

Manual Arrangement

Bi-Parting Doors

Plan View

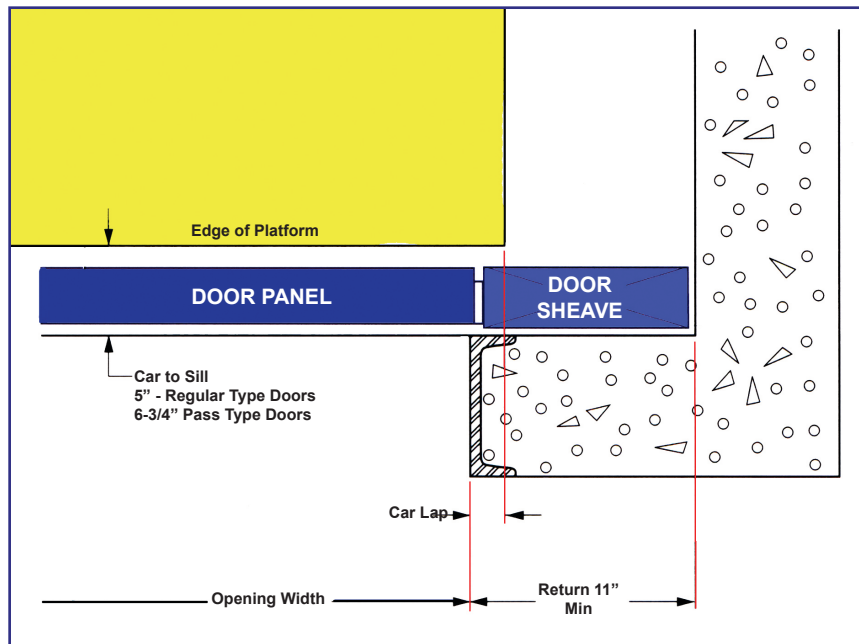

Vertical Bi-Parting Freight Doors

Vertical bi-parting doors provide full opening width access to the inside of the car, but require very little additional hoistway space. Bi-parting doors can be applied in most hoistway situations, including short spandrel heights, shallow pit, and low overheads. The counter-balance of the two (2) door panels ensures smooth operation and long motor life for power doors.

Regular Type Doors have found acceptance world wide. They are used when there is sufficient space available in the hoistway.

Pass Type Doors are used when the floor-to-floor dimension is restricted. Pass doors allow the use of Bi-Parting doors by having the upper panel at the short floor height offset to pass behind the lower panel of the door above. They are also known as Extended Sill Doors.

Telescoping Upper Section Doors are used at the top landing only, where clear overhead is low. The upper half of the door is in two (2) sections, thus reducing the clear overhead required.

Regular Type Compound Lower Section Doors (1/3 down, 2/3 up) are used when the pit is less than standard. This door reduces the pit required.

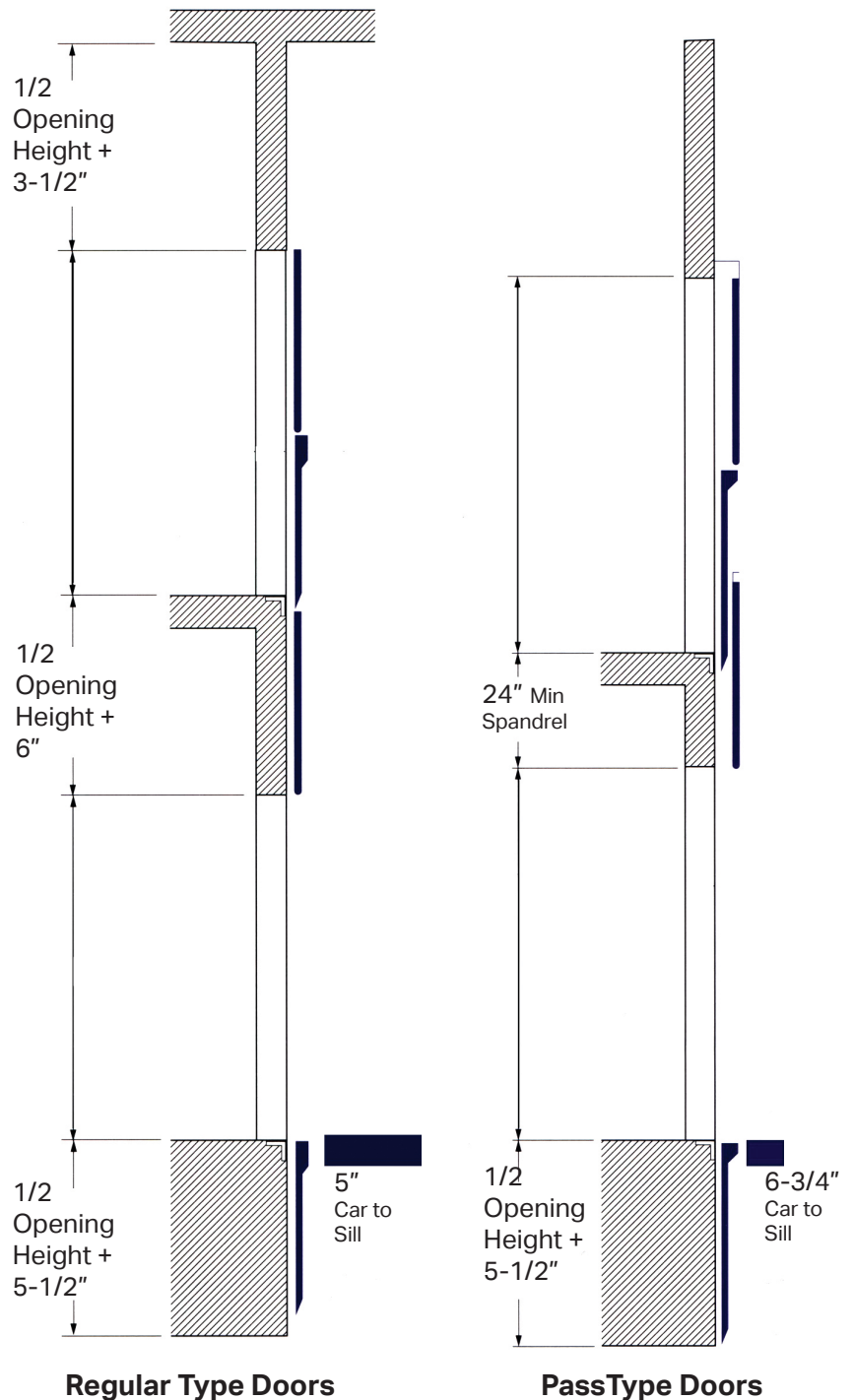

Vertical Bi-Parting Freight Doors (Cont.)

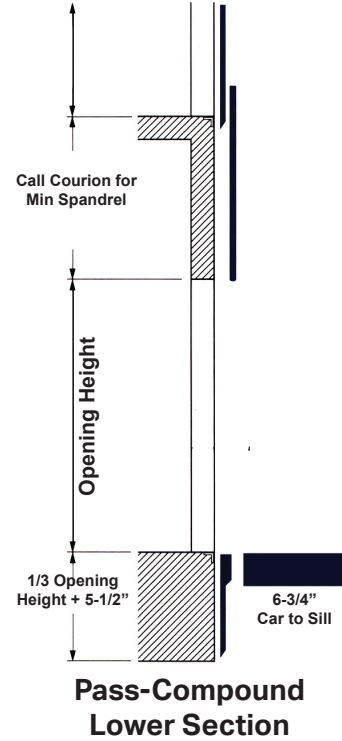
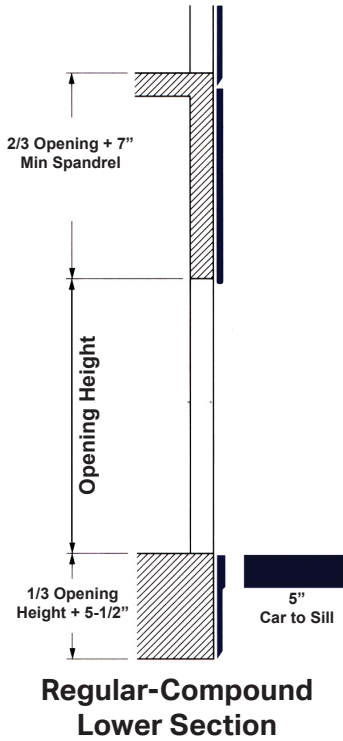
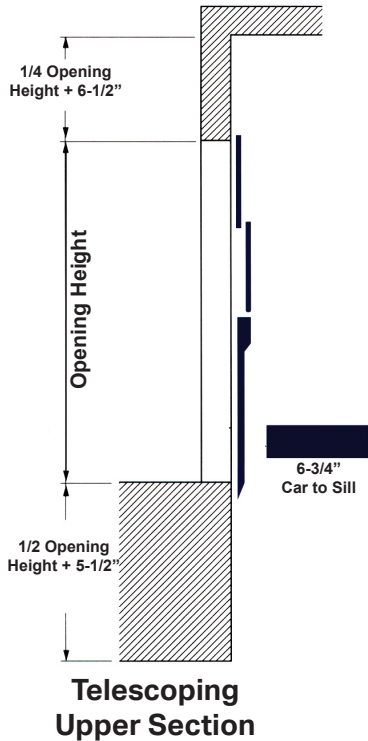

Slide-Up Freight Doors

Slide-Up Freight Doors are clearly the doors of choice in many regions. Projecting sills are always required for slide-up doors.

Single Section Slide-Up Doors can be used when the distance between the projecting sill and the underside of the projecting sill above is adequate.

Two Section Slide-Up Doors can be used when the clearance available is less than required for Single Section Slide-Up Doors

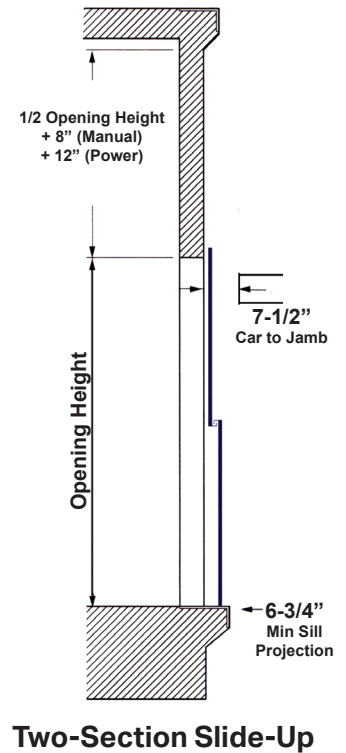
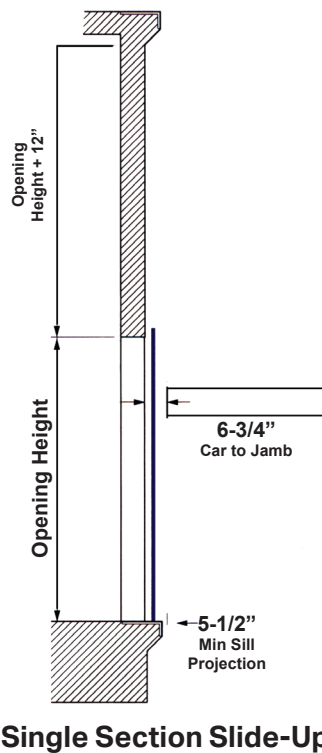

NEMA Electrical Enclosure Designations

The National Electric Manufacturing Association (NEMA) prescribes standards for electrical enclosures that relate to the environmental conditions found in freight elevator hoistways.

COURION's electrical enclosures are all NEMA 4, 12, & 13 - standard. The NEMA designations are defined as follows:

NEMA 1: GENERAL PURPOSE

Enclosure constructed for indoor use to provide a degree of protection for personnel against incidental contact with the enclosed equipment and to provide a degree of protection against falling dirt.

NEMA 4: WATER AND DUST RESISTANT

Enclosure constructed for either indoor or outdoor use to provide a degree of protection against falling dirt, rain, sleet, snow, windblown dust, and splashing water.

NEMA 4X: CORROSION RESISTANT

Same as NEMA 4 plus protection against corrosion.

NEMA 7: FLAMMABLE GASES, VAPORS OR LIQUIDS - HAZARDOUS LOCATION

Enclosure constructed for indoor use to provide a degree of protection in a vapor atmosphere defined as Class I, Group A, B, C or D of the National Electric Code.

NEMA 9: COMBUSTIBLE DUSTS – HAZARDOUS LOCATION.

Enclosure constructed for indoor use to provide a degree of protection in a combustible dust environment defined as Class II, Group E, F, or G of the National Electric Code.

NEMA 12: DUST RESISTANT

Enclosure constructed for indoor use to provide a degree of protection against falling dirt, circulating dust, lint, and fibers, and against dripping and light splashing of liquids.

NEMA 13: OIL RESISTANT

Enclosure constructed for indoor use to provide a degree of protection against falling dirt, circulating dust, lint, and fibers, and the spraying, splashing, seepage of water, oil, and non-corrosive coolants.



Loading & Classes

Bi-parting freight doors are designed to match the capacity and class of loading of the freight elevator as required by Section 2.11.12.4.2 ASME 17A.1-2000. The minimum rated load for bi-parting freight doors is based on the weight and class of the load to be handled, but in no case less than the minimums specified in Section 2.16.2 ASME 17A.1-2000. General explanations of the classes of loading are as follows:

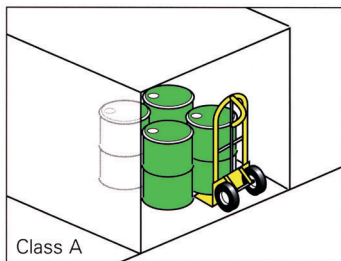

Class A: General Freight Loading

Where (1) the load is distributed, (2) the weight of any single piece of freight or of any single hand truck and its load is not more than 25% of the rated load of the elevator, and (3) the load is handled on and off the car platform manually or by means of hand trucks.

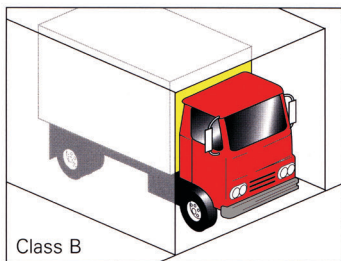

Class B: Motor Vehicle Loading

Where the elevator is used solely to carry automobile trucks or passenger automobiles up to the rated capacity of the elevator.

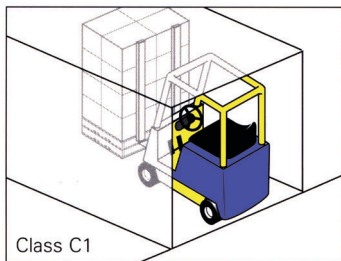

Class C-1: Industrial Truck Loading

Where (1) the industrial truck travels with the load and (2) the static load (including the industrial truck) during loading and unloading does not exceed the capacity of the elevator.

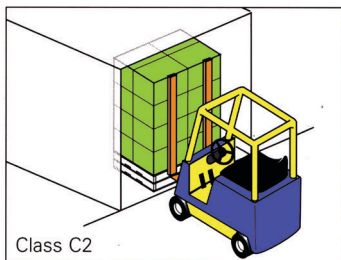

Class C-2: Industrial Truck Loading

Where (1) the industrial truck does not travel with the load and (2) the static load (including the industrial truck) during loading and unloading is permitted to exceed the rated load. However, the maximum load during loading and unloading cannot exceed 150% of the rated load.

Freight Doors & The Americans with Disabilities Act

COURION freight doors are supplied for freight elevator use only. Pursuant to ASME 17.1 - Section 3, a freight elevator is an elevator used primarily for carrying freight and on which only the operator and the persons necessary for unloading and loading the freight are permitted to ride. COURION freight elevator doors shall not be considered as meeting the requirements of the American with Disabilities Act as set forth in Appendix A of Part 36 - Standards for Accessible Design, ADA Accessibility Guidelines for Buildings and Facilities.

Freight Elevator Door Controller

COURION's "iLEARN" Door Controller is standard on all COURION power operated freight elevator door packages. The "iLEARN" Door Controller is built around an industry proven, on-board PLC with custom software that automatically adjusts the doors and car gate to ensure the smooth and quiet performance of your COURION equipment. COURION's "iLEARN" Controller offers superior VFD motor control that reduces overheating and extends the life of the door motors.

"iLEARN" Controller standard features include:

- Serial hoistway & elevator control communication
- An event log
- Fire service
- Constant pressure close or momentary pressure
- Passenger sequence operation
- Automatic close operation

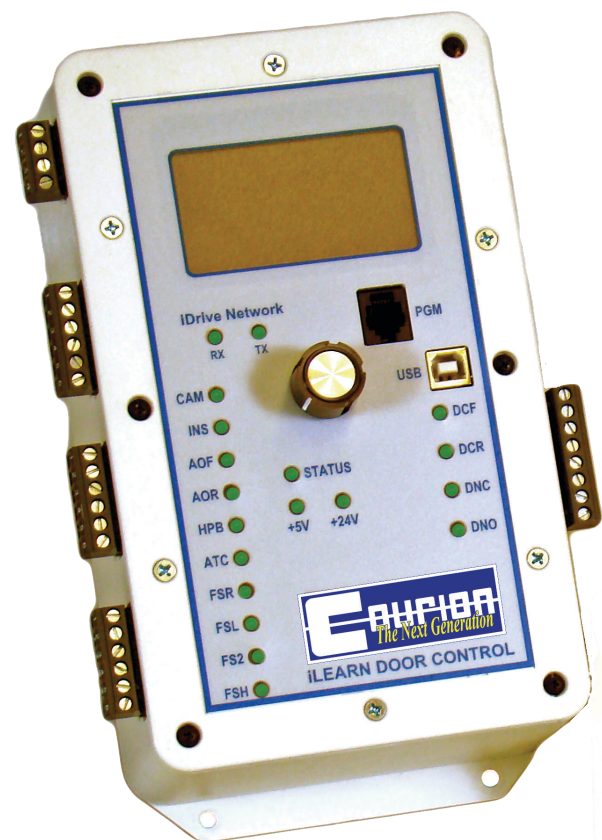

Gate System Layout

Next Generation Car Gate

COURION has designed a revolutionary new freight elevator gate system. The time required for installation and maintenance has been cut to a fraction of that required for traditional gate systems.

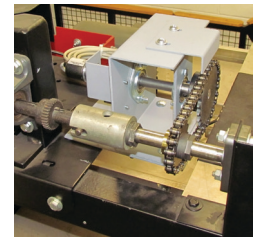
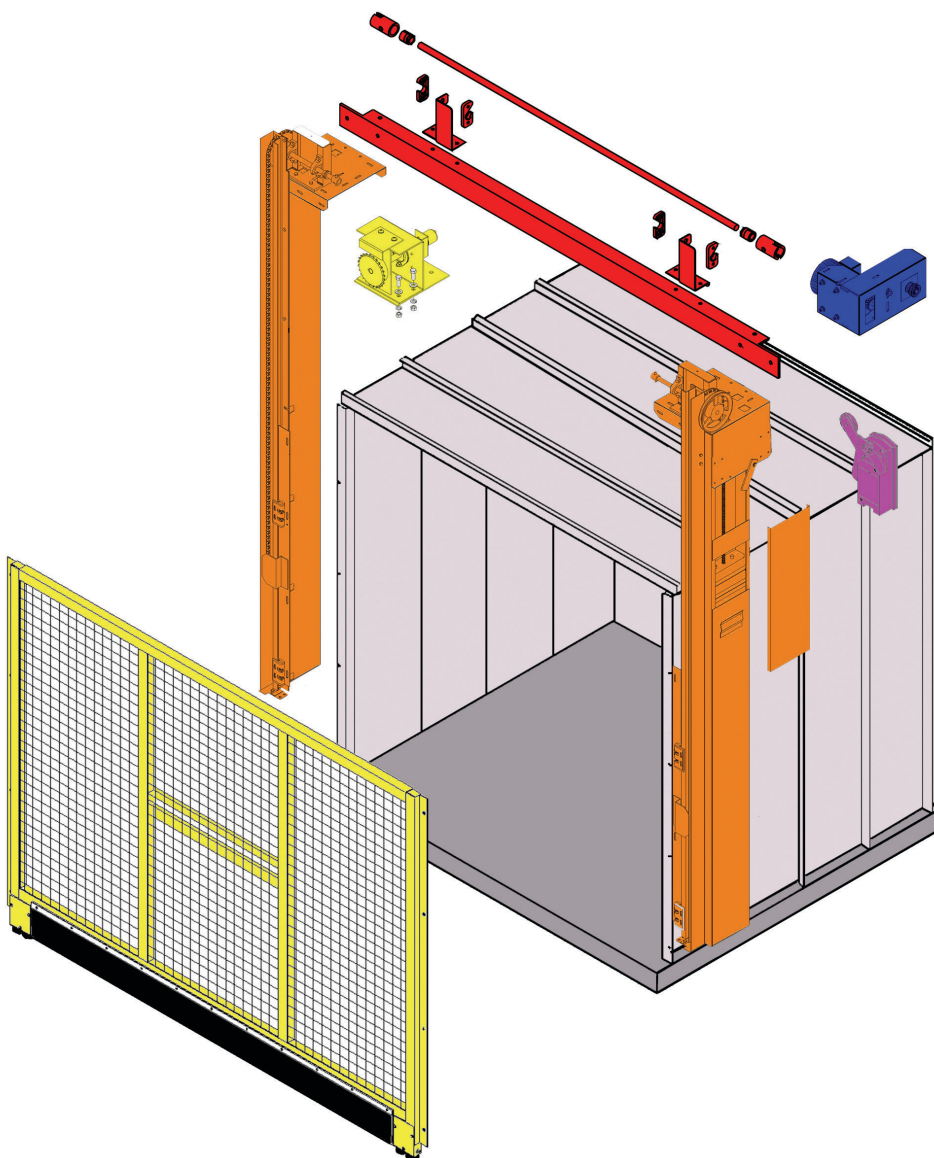

Gate iSensor



Gate Drive Unit



QGS Gate Contact



Gate Column & Cross Drive

Gate System Features

COURION has designed a revolutionary freight elevator car gate system. The time required for installation and maintenance has been cut to a fraction of that required for other gate systems. Power gate systems ship in six (6) pre-assembled modular components.

"Q" GATE COLUMN

The COURION "Q" Gate Column combines the weights, chains, gate guides, and mounting bracket in one simple-to-install unit. All adjustments are made at COURION prior to delivery.



"Q" Gate Column

GATE DRIVE UNIT

COURION's new generation of freight elevator gates eliminates parts, improves performance and durability, and substantially reduces installation time. The "Q" Style Gate Drive Unit combines the reliability of COURION's torque gate motor with a heavy-duty steel frame and sealed ball bearings, to create a Gate Drive Unit that has no equal in the industry.



Gate Drive Unit

GATE "ISENSOR"

Ready to replace those old limit switches? COURION has the answer. Introducing the Gate "iSENSOR". It's easy to install, automatically adjusts, and requires no maintenance. Like all of COURION's other electrical components, it is rated NEMA 4, 12, and 13 - standard.

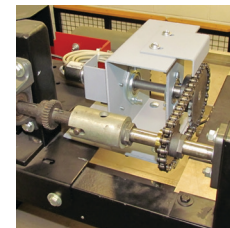

Gate "iSensor"

QGS GATE CONTACT

The COURION QGS Gate Contact introduces features which are not found anywhere else in the freight elevator door industry, but are standard on all COURION "Q" Series freight doors.



QGS Gate Contact

RETIRING CAM

This streamlined and compact design features a belt driven progressive cam - no more crank levers or air checks.



Retiring Cam

Minimum Space Requirements for Standard COURION Car Gate

COURION gates are available for either power or manual operations, and can be furnished in wire mesh or solid panel construction.

COURION wire mesh gates are fabricated of 10 gauge round wire formed in a 1-3/8" (34mm) mesh, crimped in both directions, and welded into a tubular steel frame. Note: 3/8" (9mm) mesh is available when required.

Standard gates are 6'-0" (1830mm) high. Full height gates are also available.

COURION car gates are finished in factory standard gray primer. They can also be finished with air-dry enamel or constructed of stainless steel.

Solid Panel gates are furnished standard in 18 gauge mild steel, prime painted. They are also available with air-dry enamel finish or constructed of stainless steel.

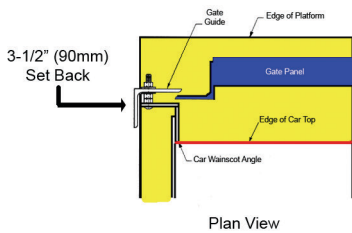

Plan View

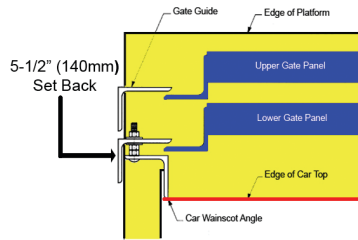

Plan View

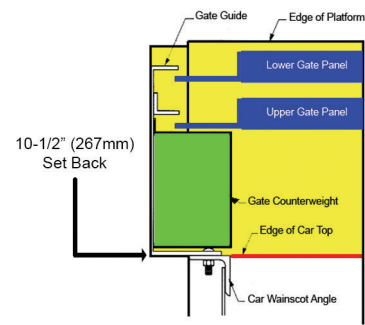

Plan View

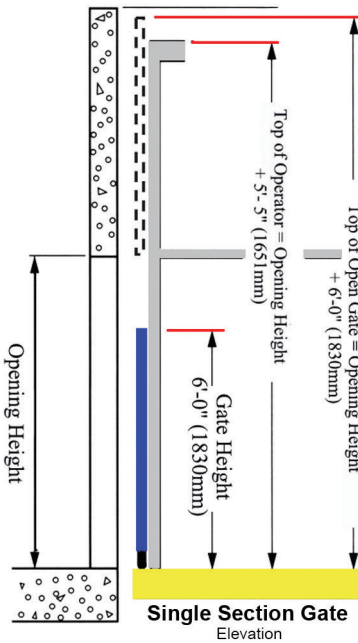

Single Section Gate Elevation

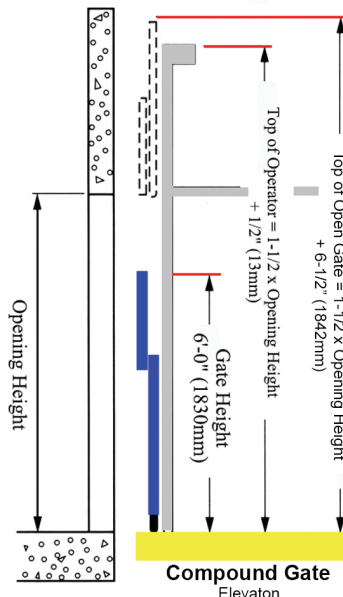

Compound Gate Elevation

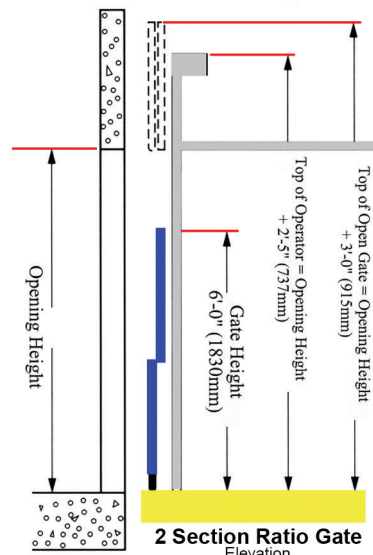

2 Section Ratio Gate Elevation

CAR ENCLOSURES

STANDARD FEATURES:

- 14 gauge enclosure walls
- 12 gauge canopy top
- Lighting fixtures to meet all applicable codes and specifications. Fixtures recessed to maintain clean, efficient, safe interiors
- Emergency exit panel hinged to the top of the car enclosure at the front
- Safety contact on exit panel
- All necessary reinforced cutouts
- Pre-drilled for COURION Gate System
- Car-to-frame anti-sway stabilizers
- Factory standard grey primer

OPTIONAL FEATURES:

- Enamel Finish
- Powder Coat Finish
- Stainless Steel Construction
- Cab Bumpers - hardwood, steel, or stainless
- Top-of-Car Handrails

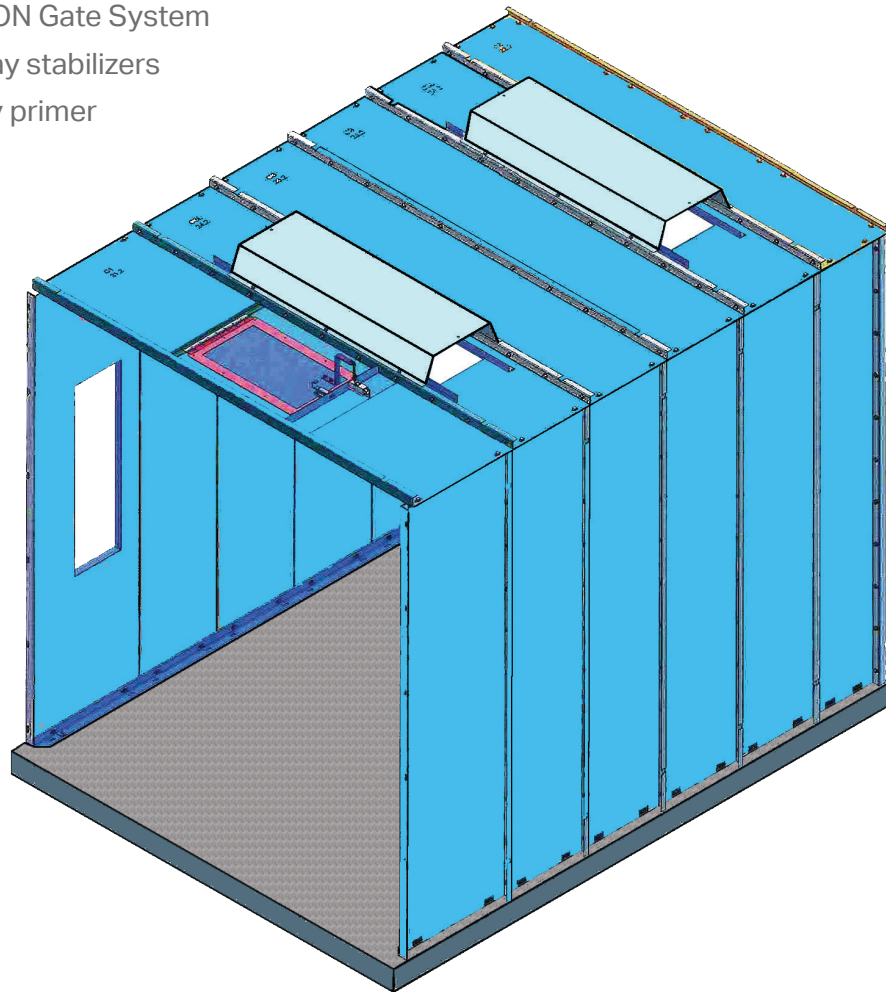

SPECIFICATIONS

1.01 GENERAL DESCRIPTION

- A. Provide elevator manufacturer's "standard" Freight Elevator Door System consisting of hoistway doors, car gate, door controller, car enclosure, and all required safety devices. All door equipment must conform to the latest edition of the ASME/A17.1 Code.
- B. General description of "standard" Freight Elevator Door System is as follows:
1. Platform size: +/- _____" wide x +/- _____" deep.
 2. Car clear inside: +/- _____" wide x +/- _____" deep x ± _____" high.
 3. Hoistway Doors and Car Gate: Power operated, single speed, vertical bi-parting, _____ wide x _____ high clear opening with all openings "in-line" unless otherwise noted.
 4. Capacity: _____ pounds, Class _____.
 5. Door Controller: A microprocessor controller shall be provided, including necessary limit and auto-stops switches together with all other components required to accomplish the operation of the doors, as specified below.

1.02 GENERAL INSTALLATION REQUIREMENTS

- A. **Sills and Frames – General:** Shaft side of frames and sills, furnished and installed by General Contractor, must be in alignment and plumb with the openings above and below. Steel entrance frames must be constructed of 6" (1.83m) or larger standard structural channels. Jambs must be a minimum of 3/16" (4.8mm) thick with a 2-1/4" (57.2mm) shaft side flange. Sills must be level to 1/8" (3.2mm) per 8'-0" (2440mm) of opening width.
1. Head and jamb sections shall be field welded or bolted together to form one-piece units. Jamb sections shall extend from floor slab to underside of structure above, and shall be securely fastened to building structure prior to construction of the hoistway walls. Frames shall be provided with air dry enamel primer suitable for application of finish paint by Owner.
 2. Hoistway door sills (furnished and installed by General Contractor) shall be constructed of hot-rolled structural steel angles as detailed and shown on the general construction drawings to be prepared by the Architect at a later date. Sill angles shall be securely anchored to the building floor.
- B. **Masonry Installation Requirements:** Doors used in masonry shaft construction must meet the following criteria, as established by Underwriters Laboratories, Inc. ("UL"):
1. Steel Plate (SP) and Steel Plate Insulated (SPI) Doors are UL labeled in sizes up to 13'-6" (4115mm) wide by 12'-0" (3658mm) high. They are UL Certified up to 16'-10-1/2" (5144mm) wide by 15'-0" (4575mm) high.
 2. Metal Clad (M-6) Doors are UL labeled in sizes up to 8'-0" (2440mm) wide by 10'-0" (3048mm) high. Metal Clad Doors are UL Certified up to 10'-0" (3048mm) wide by 12'-0" (3658mm) high.
 3. Structural steel sills, heads and jambs must be furnished and set one above the other, square with the hoistway. Jambs must be a minimum of 3/16" (5mm) thick with a 2-1/4" (58mm) shaft side flange.
 4. Sills must be level to 1/8" (4mm) per 8'-0" (2440mm) of opening width.
 5. Walls must not project beyond the frame on the hoistway side.

C. **Drywall Installation Requirements:** Doors used in drywall shaft construction must meet all of the above, plus they must be installed in a structural entrance frame. In addition, UL has more stringent size requirements for doors installed in drywall.

1. Steel Plate (SP) and Steel Plate Insulated (SPI) Doors are UL labeled in sizes up to 10'-0" (3048mm) wide by 10'-6" (3202mm) high. Doors up to 13'-6-1/2" (4130mm) wide by 13'-1-1/2" (4000mm) high must have a UL or C-UL oversize label.
2. Metal Clad (M-6) Doors must be UL and C-UL labeled in sizes up to 8'-0" (2440mm) wide by 10'-0" (3048mm) high. M-6 Doors up to 10'-0" (3048mm) wide by 12'-0" (3660mm) high must have a UL or C-UL oversize label.
3. Structural steel sills, heads and jambs must be furnished and set one above the other, square with the hoistway. Jambs must run continuously from floor to beam above, and the frame header must be bolted or welded to the jambs.
4. A UL labeled drywall interface is required with the frame.

1.03 FREIGHT ELEVATOR DOORS AND CAR GATES

- A. Hoistway doors shall be of the vertical bi-parting (including, when required, bypass bi-parting) type, counterbalanced and power operated and shall be constructed of not less than #12 gauge room side steel plates. Doors shall be fire rated as required by applicable codes, including one of the following:
1. Doors within size limitations shall bear Underwriters Laboratories, Inc. or C-UL, 1-1/2 hour class "B" label. Door panels shall be COURION type "SP" flush room side design, with welded 12 gauge room side steel plates.
 2. Doors within size limitations shall bear Underwriters Laboratories, Inc. or C-UL 1-1/2 hour, 650 degree Fahrenheit/30 minute temperature rise, Class "B" label. Door panels shall be COURION type "SPI" flush room side design, with welded 12 gauge room side steel plate and a light gauge shaft side sheet, enclosing a layer of insulation.
 3. Doors within size limitations shall bear Underwriters Laboratories, Inc. or C-UL 1-1/2 hour, 250 degree Fahrenheit/30 minute temperature rise, Class "B" label. Door panels shall be COURION type "M6" metal clad design, with two thicknesses of laminated white pine, covered on both sides with 26 gauge, lock seamed galvanized sheet.
- B. Hoistway Doors shall have the following features:
1. Door panels shall be hung with # 6 leaf chain.
 2. Doors shall have one 4" X 10" (102mm X 254mm) vision panel.
 3. The lower edge of the upper panel shall have a flexible, non-crushing, non-shearing, fire resistant astragal to provide a space of not less than 3/4" (18mm) between rigid members of the closed panels.
 4. The upper edge of the lower panel shall have a reinforced trucking bar designed to sustain the load specified for the elevator.
 5. Door guides shall be of heavy formed steel.
 6. Door panels shall be furnished with one web strap for emergency manual operation.
 7. Door panels shall have adjustable, low friction, replaceable guide shoes.

- 8.** Door panels shall be furnished with one coat of factory standard grey primer.
- 9.** Door panels shall be power operated by two COURION low profile, single speed electric motors and operators.
- C.** Car gates shall be of the single section vertical sliding type, counterbalanced and power operated. Gates shall be constructed of not less than #13 gauge steel wire mesh and supported by an adequately braced steel frame. Gate shall be guided on steel tracks and the counterweights shall be enclosed. Car gates shall include the following features:
 - 1.** Car gate mesh shall be of .135" (3.4mm) diameter high carbon steel wire, crimped in both directions in a 1-3/8" (34mm) pattern. A 3/8" (9mm) pattern may be substituted when required.
 - 2.** Car gates shall be guided in steel rails and shall have adjustable, low friction, replaceable, guide shoes.
 - 3.** Car gates shall be provided with a COURION gate contact.
 - 4.** Car gates shall be provided with one coat of standard factory grey primer.
 - 5.** Each car gate shall be power operated.
 - 6.** Each car gate and each hoistway door shall be equipped with individual electric operators so interconnected that the doors and gate shall open and close at a speed of approximately one foot (1'-0") per second without appreciable shock or jar. Car gate shall close before the hoistway doors, and the hoistway doors shall open prior to the car gate.
 - 7.** Car gate shall be equipped with an electric contact wired and connected so as to prevent operation of the elevator unless the car gate is closed.
 - 8.** Car gate shall be equipped with reversing edge(s) which will cause the hoistway doors and car gate to return to the fully open position should it encounter an obstruction upon closing. Once the hoistway doors and the car gate have returned to the fully open position after encountering such obstruction, the car gate can be closed by first releasing and then reapplying continuous pressure to the "Door Close" button.

1.04 FREIGHT DOOR AND CAR GATE OPERATIONS

- A.** The Freight elevator door system shall be designed so that the hoistway doors and car gates can open automatically as the car levels at a floor, or by momentary pressure on the "Door Open" button and continuous pressure on the "Door Close" button.
- B.** The system shall have hoistway doors that open at least two-thirds of their travel before the car gate begins to open, and car gates that close at least two-thirds of their travel before the hoistway doors begin to close.
- C.** The power operator and electric controls shall be designed to prevent electrical overload should an obstruction prevent the hoistway doors or car gate from moving with power applied. After removing the obstruction, the equipment must be capable of being returned to service immediately.
- D.** The system shall include only one door limit switch per opening, containing two enclosed contacts, which is capable of controlling both the open and close limit.
- E.** An approved interlock, containing enclosed contacts, shall be furnished for each opening.
- F.** A power retiring cam shall be furnished.

- G.** Door operator motors shall be totally enclosed and non-ventilated.
- H.** All gate switches and interlocks shall have modular, enclosed contacts, which have substantial, visible follow-up wiping action.
- I.** All limit switches, gate switches and interlocks shall be rated NEMA 4, 12, and 13 minimum.
- J.** Design shall allow immediate manual operation of the hoistway doors and car gates in an emergency, without disconnecting the power equipment.
- K.** After the car stops at a landing, a hall time relay shall render the car inoperative by all hall call buttons for a predetermined (adjustable) amount of time.
- L.** Momentary pressure on a hall call button when the elevator is parked at another landing with the doors open will cause a bell located in the car to ring, indicating that the elevator doors should be closed so that the call can be answered.
- M.** Emergency battery lowering: Elevators shall be equipped with a battery operated system which will, in the event of a power failure, loss of phase, or similar mishap in the power supply, automatically lower the car to the lowest landing and then shut the elevator down. The hoistway doors and the car gate must be opened manually either from within the car without the use of a key or tool of any kind, or from outside using code required keys. The elevator can only be restarted by turning the mainline power off and then back on after correcting the cause of the power failure.
- N.** Emergency recall and override: Elevators shall be equipped with "Phase I" emergency recall, and "Phase II" fireman's override in accordance with applicable code and as further described in the latest edition of the ASME A17.1 Code.
- O.** Hoistway doors and the car gate shall open automatically upon arrival at the floor selected. Doors may also be opened by a momentary push on the "Door Open" buttons. Doors may only be closed by applying continuous pressure on the "Door Close" buttons.
- P.** The hoistway door and car gate operators shall be so arranged that in case of interruption or failure of electric power from any cause, the doors can be readily operated by hand from within the car. Emergency devices and keys for opening the doors from the landing shall be provided as required by applicable codes.

1.05 FREIGHT ELEVATOR CAR ENCLOSURES

- A.** Car Enclosure: The car wainscot shall be of not less than #14 gauge sheet steel, properly braced and reinforced. It shall be practically flush on the inside, securely and rigidly fastened.
- B.** Car Canopy: The car top shall be of not less than #12 gauge sheet steel, so designed as to be capable of sustaining a load of 300 pounds on any 2' square area. A hinged emergency exit with an emergency exit contact shall be provided in the car top.
- C.** Car finishes: Color will be COURION Grey. All exposed surfaces on Car Enclosure (except for the car operating station) shall be air-dry enamel primer. Finish coat and color may be selected by Owner at additional cost.
- D.** Lighting: Provide fluorescent light fixtures recessed into the car top and provided with suitable guards to prevent damage from handling of cargo, but which are easily removed to provide access to the lamps and ballasts



REQUEST FOR CAB QUOTE

Elevator Contractor: _____ Address: _____

Contact Person: _____ e-mail address: _____

Phone Number: _____ Fax Number: _____

Job Name: _____ Job Location: _____

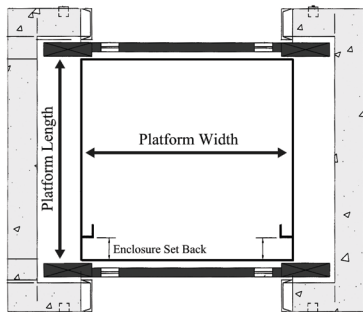

Front Opening Front & Rear Opening

Platform Width: _____' x _____"

Platform Length: _____' x _____"

Car Enclosure Height: _____' x _____"

Enclosure Set Back: _____"

BUMPERS

Wood Bumpers Steel Bumpers

Stainless Steel Bumpers Handrails

of Rows: _____ Side Rear

FINISHES

Primer Air Dry Enamel (specify color)

Stainless Steel - 2B Mill Finish Stainless Steel - #4 Finish

Other Other

OPTIONS

Top of Car Handrails: _____ Exhaust Fan: _____

Special Lighting (please describe): _____

Other: _____

REQUEST FOR DOOR QUOTE

Elevator Contractor:

Address:

Contact Person:

E-Mail Address:

Phone Number:

Fax Number:

Job Name:

Job Location:

DOOR DATA

Manual

Power

Door Construction

Steel Plate (SP)

Steel Plate Insulated (SPI)

Metal Clad (M-C)

Sound Deadening

Door Finish

Primer (standard)

Air Dry Enamel (specify color)

Powder Coat (specify color)

#4 Stainless Room-side Sheet/factory prime frame

#4 Stainless Room-side Sheet/ 2B stainless frame

2B Stainless Room-side Sheet/2B stainless frame

Options

Weather Stripping

Installation by Freight Tech

Auto-Close Operation

Wiring Package

CAR GATE DATA

Single Section Gate Two Section Gate

Wire Mesh
 Solid Panel

Standard Height (6')(1.8M)

Full Height

Primer
 Enamel (specify color)
 Stainless Steel

Infrared Automatic Reversing Edge

Other:

HOISTWAY DATA

Car Capacity:

Class of Loading:

Drywall Walls Masonry Walls

Power Supply:

Hoistway Conditions (NEMA 1, 4, 12 & 13 is standard)

NEMA 1 NEMA 4 (Moisture) NEMA 4X (Corrosive)

NEMA 7 (Explosion) NEMA 9 (Combustible)

NEMA 12 (Dust Resistant) NEMA 13 (Oil Resistant)

Control Room Conditions (NEMA 1 is standard)

NEMA 1 NEMA 4 (Moisture) NEMA 4X (Corrosive)

NEMA 7 (Explosion) NEMA 9 (Combustible)

NEMA 12 (Dust Resistant) NEMA 13 (Oil Resistant)



A VANTAGE Company

CART-MATIC CART SYSTEM

MAXIMIZE PAY LOAD PER CYCLE

Courion's CART-MATIC® Cart System maximizes your delivered payload. Our lifts are rated at 1000 lbs. capacity with a typical payload in excess of 800 lbs. Typical carts allow for up to 75 square feet of load area.

Courion's CART-MATIC® Cart System can transport a wide range of materials including: supplies, meals, mail, surgical instruments, and laundry.

MODERNIZE

Expanding or retrofitting existing systems is both feasible and cost effective. Courion's CART-MATIC® Cart System is compatible with all other brands of material handling systems. If you have an existing cart lift or dumbwaiter system that no longer meets your requirements, Courion has a solution. Courion can modernize or replace your existing AMSCO/ Guilbert Cargomaster*, Security, or Peelle Magicart** Lift Systems. Let Courion assist you in revitalizing your vertical material delivery system today.

*AMSCO/Cargomaster is a registered name of American Sterilizer

**Magicart is a registered name of The Peelle Co.

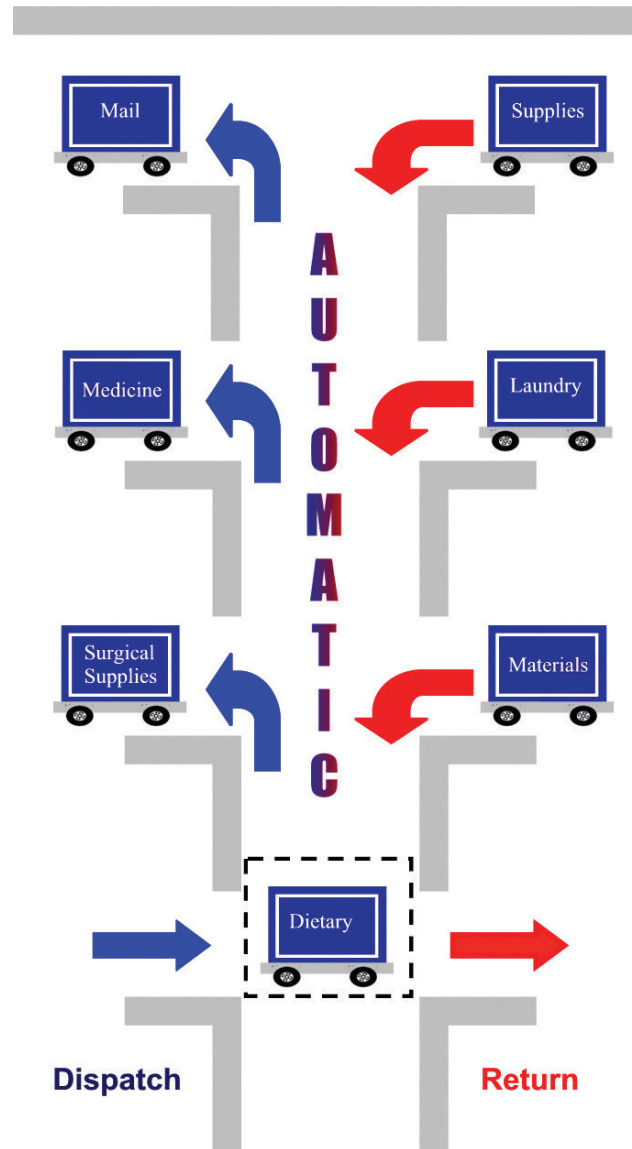

CART-MATIC TRANSFER UNIT

Courion's CART-MATIC® Transfer Unit is designed to load and eject carts consistently and automatically. After the entrance doors and car gate open, the CART-MATIC® Transfer Unit's telescoping assembly extends past the opening and mechanically couples to the underside of the cart. The cart is then automatically pulled into the car and transported to the designated Receiving Floor. Upon arrival, the cart is automatically ejected and the car is ready for its next load. Talk about saving on manpower! Courion's CART-MATIC® Transfer Unit eliminates the need for an employee to manually transport a cart from the Service Floor to the Receiving Floor, **SAVING THE OWNER BOTH TIME AND MONEY.**

CAR ENCLOSURE

Courion's CART-MATIC® car enclosure consists of #16 gauge, #304 stainless steel, #4 finish, with a recessed light fixture. A structural steel reinforced platform is integral with the car enclosure.

All Courion CART-MATIC® car enclosures are fabricated to allow for easy clean-out. There are no unnecessary seams or pockets for dirt to hide. In addition, each car enclosure is factory prepared to receive Courion's CART-MATIC® entrance doors and car gate, cart guidance roller system, cart sensors, and Courion's CART-MATIC® Transfer Unit.

ENTRANCES DOOR & CAR GATE

Courion's CART-MATIC® hoistway entrance units are completely factory assembled and consist of bi-parting roomside stainless steel insulated doors, guides, and entrance frame. Sills on the Courion CART-MATIC® hoistway entrances have recessed cart caster dimples to receive carts. Door jambs are equipped with cart guidance roller assemblies to help guide the cart into the car enclosure.

Courion entrances bear a 1-1/2 hour Underwriters Laboratory "B" label and can be used with either drywall or masonry wall construction.

CART GUIDANCE ASSEMBLIES

Courion's Cart Guidance System starts with the cart caster dimples in the entrance sill plates, moves to the jamb roller guides, and ends with the cart roller assemblies on the side walls of the car enclosure. All are designed to coordinate with one another to ensure the consistent and automatic loading and unloading of the material carts.

DOOR PROTECTION

All Courion CART-MATIC® hoistway entrances are protected by the Courion CARE Automatic Reversing Edge which is attached between the hoistway entrance doors and car gate. The Courion CARE Automatic Reversing Edge is a non-contact light curtain that fills the opening with infra-red light beams. The CARE is an effective solution for reducing damage caused by the movement of the cart. Courion's CARE Unit is easy to install and can be added to almost any existing automatic or manual cart system.

CART-MATIC CONTROLLER

Courion's CART-MATIC® Door and Transfer Unit Control is built around an industry proven programmable PLC. Each Courion Controller is customized to your facility's unique operational procedures. Courion's controller provides the "smarts" to fully operate the doors, transfer unit, and other operations needed for proper performance of the Courion CART-MATIC® System.

CART SENSOR SYSTEM

Lobby Full Sensors prevent cart gridlock. Courion's CART-MATIC System utilizes information from the Lobby Full Sensors to determine whether there is adequate space at the destination floor for the dispatched cart. Cart-ON Sensors ensure that the CART-MATIC System runs efficiently and with the maximum payload. When a dispatched or return call is registered, the Cart-On Sensors will prevent the

lift from leaving the designated floor until the cart is on board and ready to travel. Courion's Cart READY Sensors perform two important tasks. First they reduce cart loading problems by indicating to the users that the cart has been properly positioned and is READY for dispatch or return. Second, the Cart Ready sensor may act as the automatic call button. for the CART-MATIC Cart System.

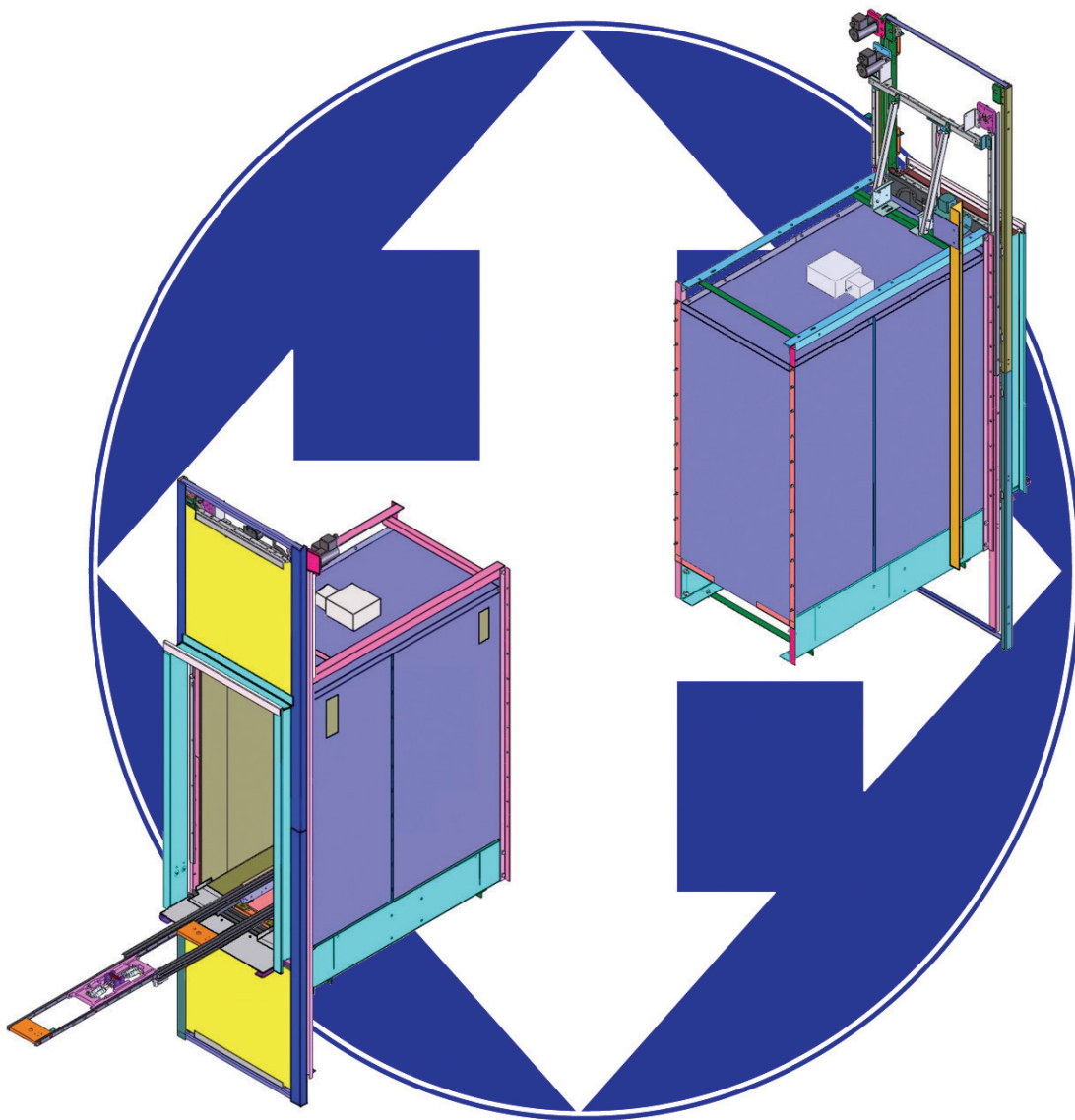

The CART-MATIC Benefits

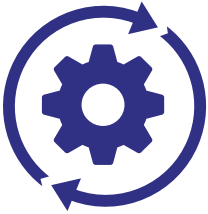

ECONOMY THROUGH AUTOMATION

How much expensive manpower is wasted waiting for the elevator, riding the elevator, and then visiting with the personnel at the Dispatch Floor? Let Courion's CART-MATIC Automatic Cart System **SAVE YOU MONEY!**



24/7 PERFORMANCE

Courion's CART-MATIC Cart System can be operated 24 hours per day, 7 days per week. Delivery Schedules are programmed to meet your needs without being restricted by your peak loading requirements on your passenger and service elevators. Key management personnel have total control of the material distribution system.



STRONG. DURABLE. DEPENDABLE.

Courion's CART-MATIC Cart System is built to last. When routine maintenance is required, all parts are easily accessible and readily available.

DUMBWAITER SURVEY

Lift#: _____

Approximate Vintage: _____

Designation: Clean or Soiled

Use: Dietary Surgical Central Supply

Counter Height: _____ Floor Loading: _____

Capacity: _____

Travel, if available: _____

Traction or Hydro

Number of Stops: _____

Number of Openings: _____ Front _____ Rear

Existing Jamb Opening Dimensions, Width: _____ Height: _____

Pit Depth, Front: _____ Rear: _____

Door & Jamb Finish: Grey Epoxy or Stl. STI. #4

Car door Finish: Grey Epoxy or Stl. STI. #4

Platform dimensions, Width: _____ Depth: _____

Original/Existing Ejector, Yes No

Manual Doors Power Doors

PROGRAM TYPE

Dispatch & Return Dispatch Only

Call Send Return Only

Existing Hoistway Door Equipment:

Security/Courion Amsco/Guilbert Peelle

Sedgwick Matot

Elevator#

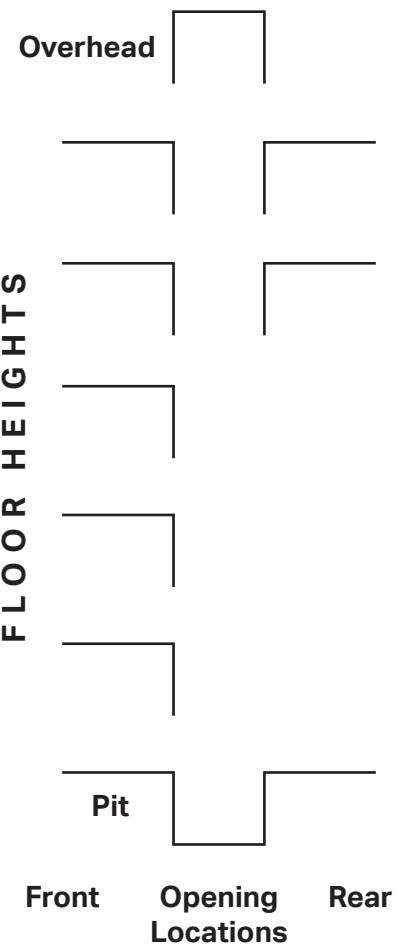

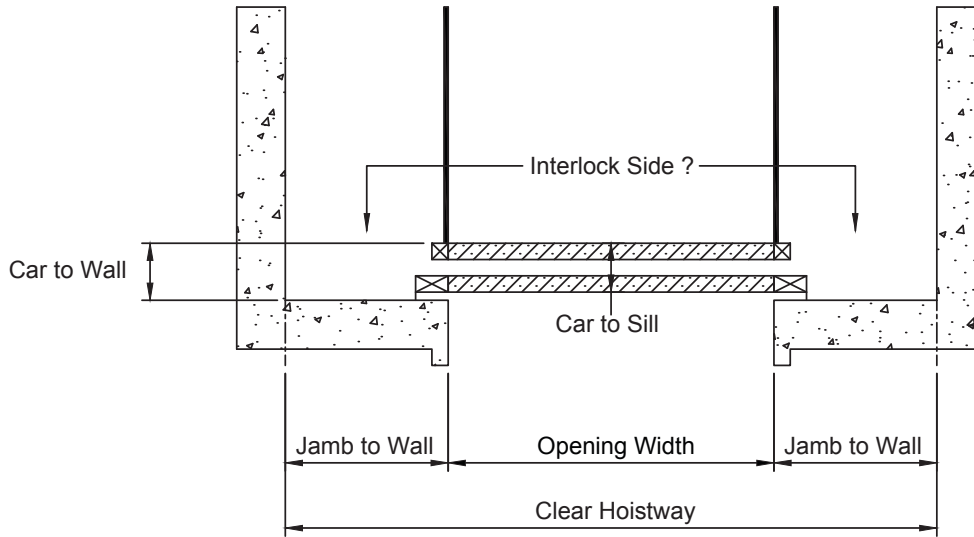

Plan View

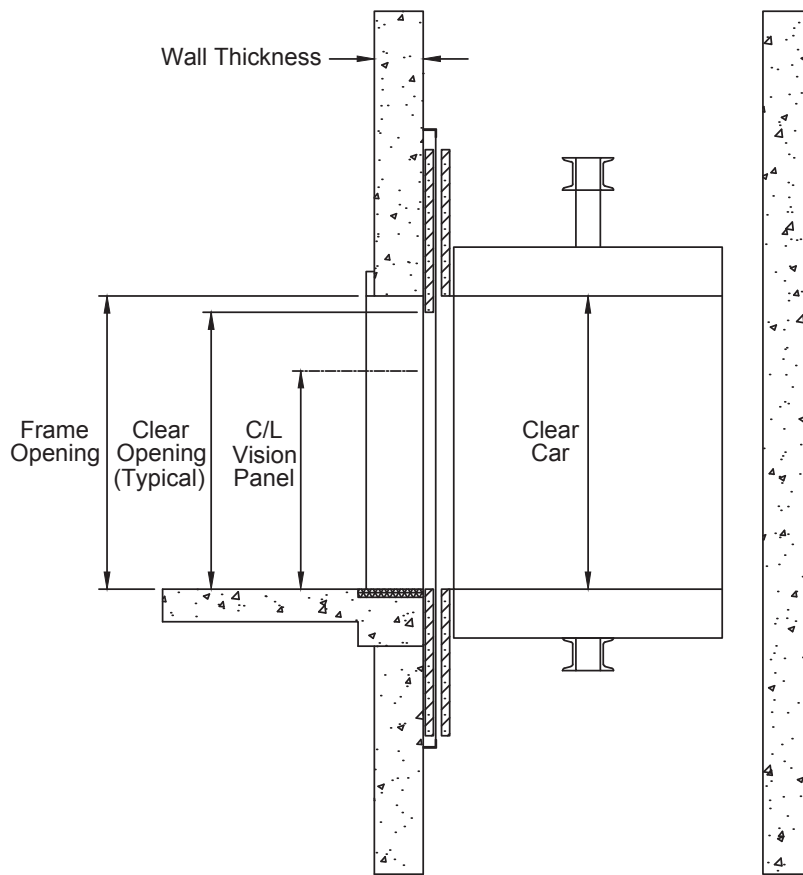

Elevation View

Startup Wizard
Set Hoistway
Params and more.
press to cont.

iDrive Network

RX TX

PGM

CAM

INS

AOF

AOR

HPB

ATC

FSR

FSL

FS2

FSH

STATUS

+5V +24V

USB

DCF

DCR

DNC

DNO

CAUTION
CAUTION
iLEARN DOOR CONTROL

ONE COMPANY SO MANY OPTIONS



Freight Door Systems



Freight Car Enclosures



IUEC Installation



Car Lift Systems



Service Parts



Service Parts



HARRIS PREBLE

Service Parts



Service Parts



A **VANTAGE** Company

3044 Lambdin Avenue
St. Louis, Missouri 63115
(800) 533-5760 or (314) 533-5700
(314) 533-5720 (fax)
sales@couriondoors.com
www.couriondoors.com

**VANTAGE REGIONAL
SERVICE CENTERS**
Miami – 877.241.9354
Chicago – 877.300.5830
Los Angeles – 877.300.5816
New York – 347.226.4555
Toronto – 888.425.2262